

AC servomotors with permanent magnets

Typ
Type
Typ

General

AC servomotors with permanent magnets are intended for up-to-date electronically controlled electric drives with a wide control range, good dynamical properties and a high precision and can be applied in the field of mechanization and automation of manufacture, packaging technique, etc. These servomotors are three-phase synchronous motors with excitation by permanent magnets on the rotor operating as brushless DC electric motors. This function of the motors is ensured by transistor converters with DC intermediate circuit and feedback control by a position sensor (e.g. resolver) embedded in the servomotor.

Basic diagram of the drive with an AC servomotor :

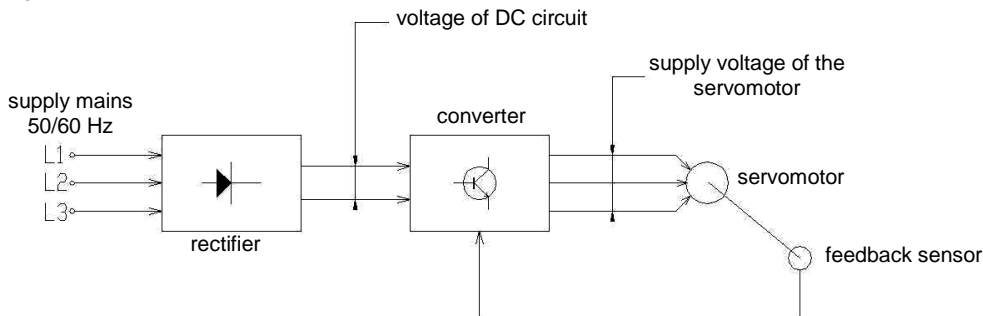

AC servomotors with rare-earth permanent magnets with a high energy density have the following benefits in comparison with standard machines:

- small dimensions and masses
- low moments of inertia
- high torque overload capability
- high efficiency
- high acceleration in transient conditions

Other features of brushless AC servomotors are as follows:

- long service life and high reliability in operation
- minimum maintenance (no sliding contacts, bearings with permanent grease filling)
- mechanical dimensions in the precise class
- increased degree of protection IP65
- fixed bearing at the side of the shaft extension

Range of servomotors of the firm VUES Brno a.s.

AC servomotors are produced in two design modifications:

- M series** – servomotors with a small ratio of diameters of the fixing flanges to the motor length (long motors)
- F series** – servomotors with a high ratio of diameters of the flanges to their length (flat motors)

Both series are produced with power output parameters for natural cooling IC 00-41 in the torque range from 0,4 to 55 Nm, mostly with 6 poles. We have been producing also machines with the number of poles 4, 8, 10 and 16.

Besides the basic version the servomotors of M series are made also in modifications for separate cooling, e.g.:

- W series** – consists of several types of the servomotors of M series modified for separate water cooling ICW37-A41; higher permanent torques and power outputs are achieved while maximum values of currents and torques are not changed

M 25

M 40

M 50

M 71

M 90

F 50

F 63

F 80

F 100

W 25

W 40

W 50

W 71

W 90

ML 40

ML 50

ML 71

ML 90

MA 40

MA 50

ME

FE

Typ Type Typ
M 25
M 40
M 50
M 71
M 90
F 50
F 63
F 80
F 100
W 25
W 40
W 50
W 71
W 90
ML 40
ML 50
ML 71
ML 90
MA 40
MA 50
ME
FE

- ❑ **ML series** – consists of several types of the servomotors of M series modified for the cooling by surface air flow from a separate fan IC 06-41, also with higher permanent torques and power outputs
- ❑ **ME series** – consists of the servomotors of M series intended for built-in version
- ❑ **FE series** – consists of the servomotors of F series intended for built-in version
- ❑ **MA series** – consists of servoactuators based on the servomotors of M series. It is a standard series of servomotors with a hollow shaft into which a ball screw is built. This design enables transmission of rotating to linear movement to be achieved while maintaining small outside dimensions.

All types of the servomotors can be delivered also in the version with integrated electromagnetic safety brake. Servomotors are produced for three voltages of DC intermediate circuit 120, 330 and 560 V DC, r.m.s. values 70, 190 and 330 V AC being determined as rated supply voltage of servomotors U_1 . The servomotors with intermediate circuits of the voltage 560 V DC are provided with reinforced phase insulation. The servomotors were designed for being supplied from converters of the firm Bautz, they can be supplied, however, also from converters of other firms.

The rated speed of servomotors is determined for the rated voltages given above and for the fixed range of voltage constants K_E being given in the servomotor type (see Ordering of servomotors).

The German firm Eduard Bautz GmbH is an exclusive supplier of these servomotors into EU countries on the basis of a contract. Further export of servomotors delivered to the Czech market into these countries is therefore inadmissible or possible only by agreement with the producer of servomotors.

Notes:

- ❑ Rated values (M_n , P_n) depend on the type of the supply converter being used and on the possibility of removing the motor losses through its flange. For the M series there is recommended roughly a minimum additional cooling area to which the motor is attached by means of its flange and which is given by the square of the side $a = 2,5 \times$ dimension of M servomotor. The temperature of the motor flange must not exceed $+90^\circ \text{C}$ in operation.
- ❑ For the servomotors of F series the dimensions of the cooling area are prescribed as follows:
 - F50 – F63 : 300 x 300mm
 - F80 – F100 : 400 x 400mm
- ❑ The binding values can be determined only for concrete combinations of the servomotor and the converter and for the relevant application of the drive.
- ❑ In case of the servomotors of W and ML series the rated parameters are binding for the rated cooling (without additional cooling areas).
- ❑ The tolerances of technical data being valid for servomotors with permanent magnets are $+10\%$. These tolerances, in addition to the manufacturing tolerance, include also the tolerances of parameters of permanent magnets, their thermal dependence and influence of temperature rise of the servomotors at the load.

General technical data of the basic version of servomotors

Types of construction and version of servomotors

- ❑ Type of construction of servomotors – according to ČSN EN 60034 -7
 - IM B5 (IM 3001)
 - IM V1 (IM 3011)
 - IM V5 (IM 3031)
- ❑ Version according to degree of protection
 - podle ČSN EN 60034-5
 - IP65 as a standard – with the exception of the shaft extension
 - IP65 by request including the shaft extension (with a sealing ring)

Cooling of servomotors

- ❑ basic version – M and F series – IC 00-41, i.e. closed, with natural cooling of the servomotor surface
- ❑ special version – W series – ICW 39-A41, i.e. water cooling in the servomotor frame
- ❑ special version – ML series – IC 06-41, i.e. closed, with cooling by air flowing over the servomotor surface from a separate fan being a part of the servomotor

Working conditions

The servomotors are designed for stationary applications at the places being protected against weather influences and for environmental conditions IE 34 according to ČSN EN 60721-3-3. Among others, the basic conditions are as follows:

- ❑ ambient temperature +5 to +40° C
- ❑ relative humidity 5 to 95 %
- ❑ altitude above sea level up to 1000 m (pressure 90 kPa)
- ❑ water cooling must be realized with treated water without mechanical impurities. The recommended hardness of water is 0,7 mmol/l. If necessary, water softening agents must be used. The recommended acidity of cooling water is in the range of 6,5 – 7,5 pH. The inlet water temperature is +5 to +25° C. The cooling water quantity is from 1 l/min to 2,5 l/min at the pressure drop from 1 to 10 kPa, according to the servomotor size. The cooling system is designed for the maximum pressure of 1 MPa.

Other technical data:

- ❑ Thermal insulation class „F“ according to ČSN 35 0000, Part 1, maximum temperature rise of the winding $\Delta \vartheta = 105$ K
- ❑ Three-phase winding in star-connection without neutral being brought out
- ❑ Thermal protection
 - one thermal switch +135° C (opening contact) located in the end winding between two phases
 - by request also other sensors, e.g. PTC etc.
- ❑ Connection of the motors to the converter:
 - power outlets: by means of a 6-pole connector, in the sizes with higher power outputs M71, M90 by means of the terminal board
 - signal outlets: by means of a 12-pole connector
 - by request outlets by the cable
- ❑ Dimensions of flanges and their tolerances
 - according to ČSN IEC 72 – 1 (350040) with the exception of the size M25
 - run-out of the shaft extension – precise class „R“ according to DIN 42955
 - axial alignment of the centring step diameter and perpendicularity of the flange seating face with regard to the shaft – precise class „R“ according to DIN 42955
- ❑ Shaft extensions
 - cylindrical without keyways with dimensions according to ČSN IEC 72 – 1, clause 7
 - by request also with keyway and feather according to the same standard
- ❑ Permissible axial and radial loads in the middle of the shaft extension for the specified average speed of the motor are given for individual types of motors in the tables of technical data of servomotors. More detailed information will be given by request.
- ❑ Rotor mounting – ball bearings with permanent grease filling for the service life $\geq 20\ 000$ hours
- ❑ Vibration
 - highest permissible values in the whole speed range (measured according to ČSN 350000, Part 14)
 - $V_{ef} = 1,8\ \text{mms}^{-1}$ at the places according to the standard
 - $V_{ef} = 2,8\ \text{mms}^{-1}$ at any place and any direction of vibration
- ❑ Surface finish
 - varnishing, black colour
 - by request surface finish for food-stuff industry (Krautoxin, black colour)

Typ
Type
Typ

M 25

M 40

M 50

M 71

M 90

F 50

F 63

F 80

F 100

W 25

W 40

W 50

W 71

W 90

ML 40

ML 50

ML 71

ML 90

MA 40

MA 50

ME

FE

Typ
Type
Typ
M 25
M 40
M 50
M 71
M 90
F 50
F 63
F 80
F 100
W 25
W 40
W 50
W 71
W 90
ML 40
ML 50
ML 71
ML 90
MA 40
MA 50
ME
FE

Feedback sensor

As a standard the servomotors are delivered with a two-pole resolver located at the front side of the servomotor (it is accessible after removing the front cover). In the basic version resolvers with the input voltage of $7 V_{ef}$, 10 kHz are applied.

By request of the customer it is possible:

- to use the type of resolver according to the requirement of the customer
- to modify the shaft at the front side of the servomotor with regard to an additional mounting of another sensor (e.g. of the firms Heidenhein, Stegmann, etc.), or mounting of a sensor other than resolver: (SinCoder, DiCoder, incremental sensor).

Safety brakes

The servomotors of all types being delivered can be ordered in the version with an integrated electromagnetic safety brake. The function of the safety brake consists in locking the rotor of the servomotor in a certain position until DC supply voltage of 24 V is connected to the brake coil. The brake can be connected and disconnected only when the rotor – drive is at rest.

The servomotors of M series have safety brakes of the type MY built in the motor frame at the rear side (at the shaft extension). The brakes are made of half-finished products of the firm MAYR. In the type size M90 a built-in version of the brake of the firm Binder is used. In the servomotors of F series there are used original brakes of the firm MAYR being mounted under a special cover at the front side of the servomotor (behind the resolver). When the resolver is adjusted in these motors the brake must be dismantled.

Instructions for assembly and operation of servomotors

Mounting of rotors of the servomotors is rated for the service life longer than 20 000 hours. The mounting is very precise, requiring a careful handling. Particularly axial forces higher than the prescribed ones or even axial impacts at the shaft extension can damage bearings or sensors and decrease their service life. That is why in the axis of the shaft extension there is a threaded hole that can be used for the mounting of couplings, pulleys or pinions. These parts must be pulled down also very carefully (tools for pulling-down).

In the servomotors with built-in safety brakes it must be ensured that the safety brake is released during the starting of the motor; it is realized after the application of electric voltage to the winding of the brake coil (locking of the rotor is carried out mechanically – by means of springs).

The temperature of the servomotor surface reaches the value of approx. $+100^{\circ} C$ in the fully utilized machines. The operators must know it.

The servomotors can be stored in dry rooms at the temperatures $-30^{\circ} C$ to $+85^{\circ} C$.

The shaft extensions must be protected against corrosion during the storage.

Torque-speed characteristic of AC servomotors

Generally the servomotors of M and F series are designed more for dynamical processes in the wide speed range with a variable load than for continuous running duties S1 with the constant load and constant speed. That is why the servomotors can be loaded by substantially higher torques (currents) than there are rated ones provided that their mean r.m.s. value does not exceed rated values for continuous running duty S1. From the electromagnetic point of view the motors are designed for 3,5 to 4 multiple of the torque overload capacity.

Torque-speed characteristic of AC servomotors

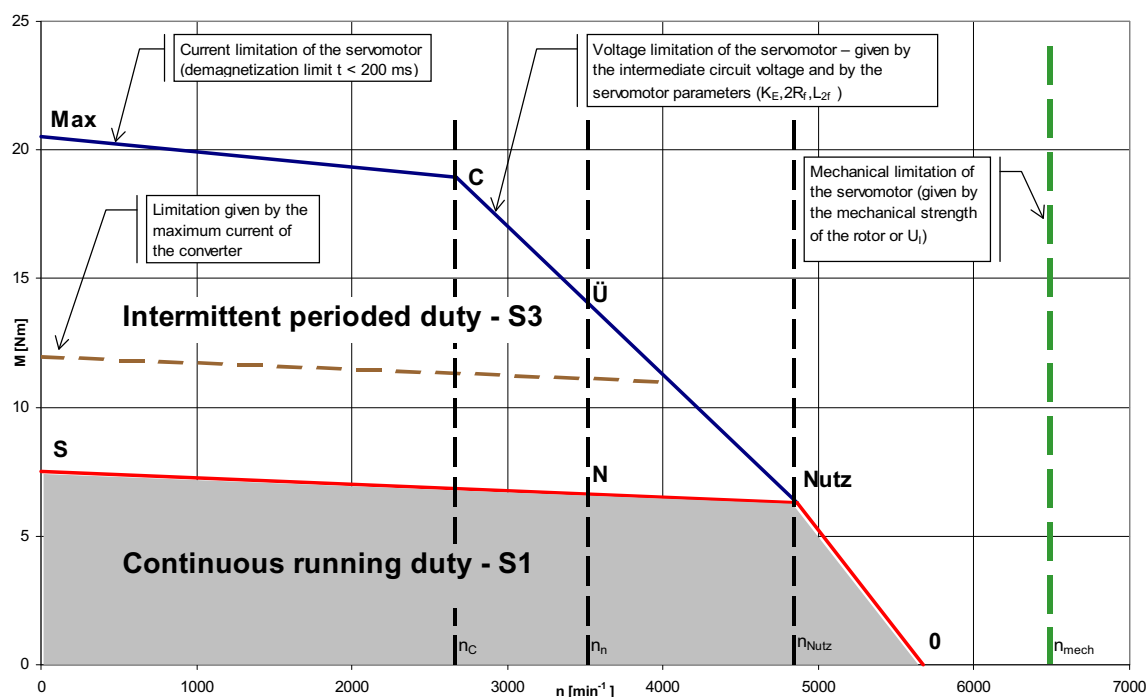

Used symbols

M_0 [Nm] - standstill torque - torque on the servomotor shaft at zero speed for continuous running duty S1 (defined for temperature rise of the winding 105 K and for the rated value of K_E)	I_{max} [A] - highest permissible servomotor current (r.m.s. value) at which the permanent demagnetization of magnets does not yet occur ($t \leq 200ms$)
I_0 [A] - standstill current - r.m.s. value of the servomotor current for standstill torque M_0	n_{max} [min^{-1}] - highest continuous permissible servomotor speed for which the rotor of the servomotor is mechanically dimensioned in hot state (or maximum permissible speed with regard to induced electromotive force in the check test)
K_M [$Nm \cdot A^{-1}$] - torque constant $k_M = M_0 / (I_0 \cdot \sqrt{3}) = k_E$ is defined for the temperature of the servomotor including magnets +20° C	R_{U-V} [Ω] - winding resistance between two terminals of the servomotor - corresponds to a double of the phase resistance at the temperature +20° C
U_1 [V] - rated maximum supply voltage of the servomotor	L_{U-V} [H] - winding inductance between two terminals of the servomotor - corresponds to the inductance of two phases connected in series, measured at the frequency 1 kHz
U_{NMOT} [V] - rated line-to-line voltage of the servomotor - r.m.s. value of the 1 st voltage harmonic at M_N and n_N (defined for the rated value of K_E and winding heated to permissible rated temperature rise)	J [$kg \cdot m^2$] - intrinsic moment of inertia of the rotor with a resolver (without a brake)
M_N [Nm] - rated torque - continuous torque on the servomotor shaft at n_N and U_N for continuous running duty S1 (defined for temperature rise of the winding 105 K and for the rated value of K_E)	m [kg] - mass of a standard servomotor including a resolver (without a brake)
I_N [A] - rated current - r.m.s. value of the servomotor current for M_N and n_N	F_A [N] - permissible axial loading of the shaft extension for continuous speed n_{mit} and horizontal mounting
n_N [min^{-1}] - rated servomotor speed	F_R [N] - permissible radial loading of the shaft extension (acting in the middle of the shaft extension length) for continuous speed n_{mit} and horizontal mounting
P_N [W] - rated power output on the servomotor shaft at M_N and n_N	n_{mit} [min^{-1}] - mean speed of the servomotor for which the values F_A and F_R are determined
M_0 [N_m] - maximum torque overload capacity at the rated speed	n_0 [min^{-1}] - maximum speed in no-load operation of the servomotor at the rated supply voltage U_N
M_{Nutz} [N_m] - maximum usable continuous torque on the servomotor shaft at the supply voltage U_1	I_C [A] - maximum short-time permissible current (r.m.s. value) which is given by the intersection of current limitation of the servomotor and of limitation by the rated voltage of the converter - LIMITING POINT C; mostly I_C is identical with the highest permissible servomotor current (I_{max})
n_{Nutz} [min^{-1}] - servomotor speed at M_{Nutz}	M_C [Nm] - maximum torque of the servomotor at the current I_C and speed n_C
P_{Nutz} [W] - maximum continuous power output of the servomotor at the supply voltage U_1	n_C [min] - speed of the servomotor at I_C and M_C
K_E [$V \cdot min^{-1} / 1000$] - voltage constant of the servomotor (rated value). r.m.s. value of line-to line induced electromotive force between two terminals of the servomotor at the speed 1000 min^{-1} and servomotor temperature +20° C	
M_{max} [Nm] - maximum torque on the servomotor shaft at zero speed and the current I_{max}	

Typ
Type
Typ

M 25

M 40

M 50

M 71

M 90

F 50

F 63

F 80

F 100

W 25

W 40

W 50

W 71

W 90

ML 40

ML 50

ML 71

ML 90

MA 40

MA 50

ME

FE